

Pioneer Prime

PP88S12L71



Typical Pump Configuration

Performance

Pioneer Prime series - vacuum assisted, end suction centrifugal pump

Bare shaft, frame mounted, fully automatic dry priming, vacuum assisted, run dry, heavy duty solids handling pump

Size	8" x 8" 200 x 200 mm
Flow, Max	4,500 USgpm 1040 m ³ /h 280 l/s
Head, Max	175 feet 50 meters
Flow at BEP	2,600 USgpm 600 m ³ /h 160 l/s
Efficiency at BEP	70%
Solids Handling, Max	3.0" 76 mm
Operating Speed, Max	2000 rpm
Suction Connection	8" (200 mm) 150 ANSI Flanges
Delivery Connection	8" (200 mm) 150 ANSI Flanges
Bearing Lubrication	Oil STD Grease optional
Fasteners	Imperial

Applications

Construction	Waste Water
Industrial	Power Generation
Mining	Environmental

High flow, solids handling heavy duty pump

The PP88S12 is a high flow, ruggedized pump designed to operate over a broad range of performance while delivering outstanding suction lift. The rugged construction and modular design provide proven reliability and flexibility in the most demanding applications.

UltraPrime™ Priming System

Priming System	Mechanically Driven Diaphragm Style Vacuum Pump
Air Removal Capability	50 CFM
Priming Chamber	Single chamber with positive sealing air separation PosiValve™ with stainless steel float ball & linkage.
Discharge Check Valve	Swing Style - ductile iron with Buna-n Disc

Other Specifications

Mechanical Seal	Single seal w/ tungsten carbide vs. silicon carbide seal faces, Viton® elastomers, 300 series stainless steel hardware and spring, designed for indefinite dry running
Pump End Bearing	Single row ball
Drive End Bearing	Double Row Angular Contact
Shaft	17-4 PH Stainless Steel

Construction Materials

	Standard Construction	CD4MCu Stainless Steel
Impeller	CA6NM SS	CD4MCu
Volute	Ductile Iron ASTM A536 65-45-12	CD4MCu
Wear Ring	ASTM A48 Class 40 Gray Iron	316 SS
Suction Cover	Ductile Iron ASTM A536 65-45-12	CD4MCu
Bracket	Ductile Iron ASTM A536 65-45-12	CD4MCu
Backplate	Ductile Iron ASTM A536 65-45-12	CD4MCu

Mechanical Dimensions



Typical Pump Configuration

PP88S12

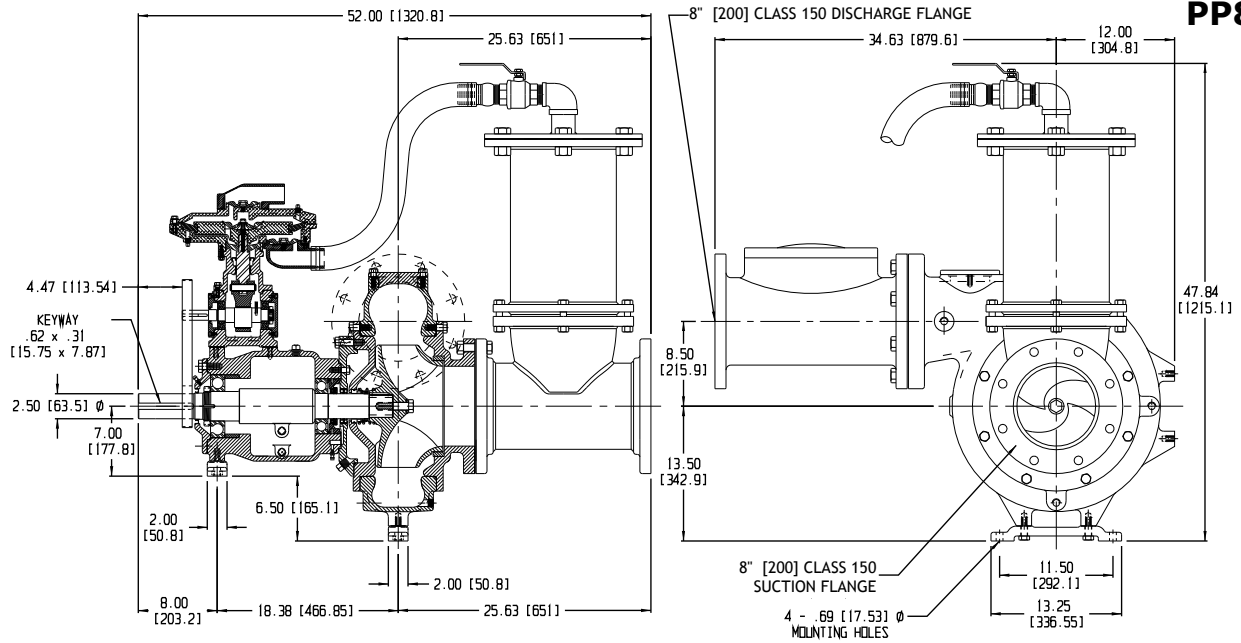

Performance Curve

Model: PP88S12	Impeller Dia: 12.5"	Speed: Variable	Solids Size: 3.0"	Curve #A4631HQ
----------------	---------------------	-----------------	-------------------	----------------

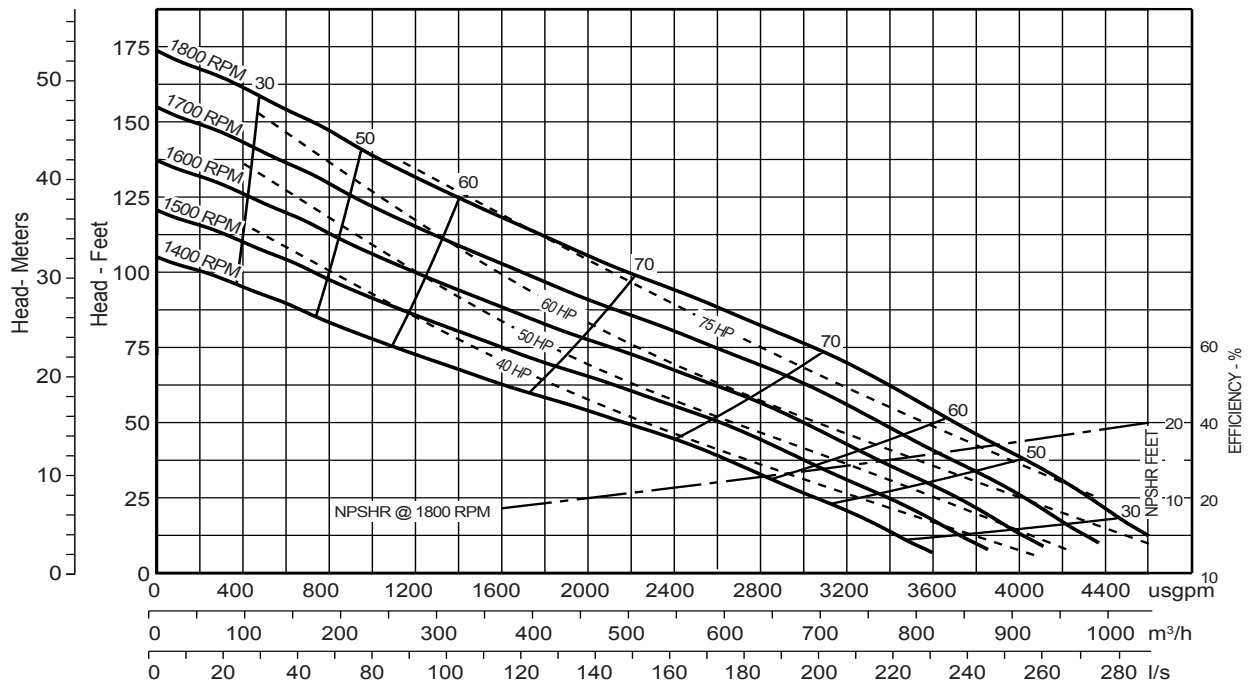

Note: Losses from priming system not shown